

SECTION 20

SYNC PULSE SEPARATION AND MONITOR PANEL PA1/520

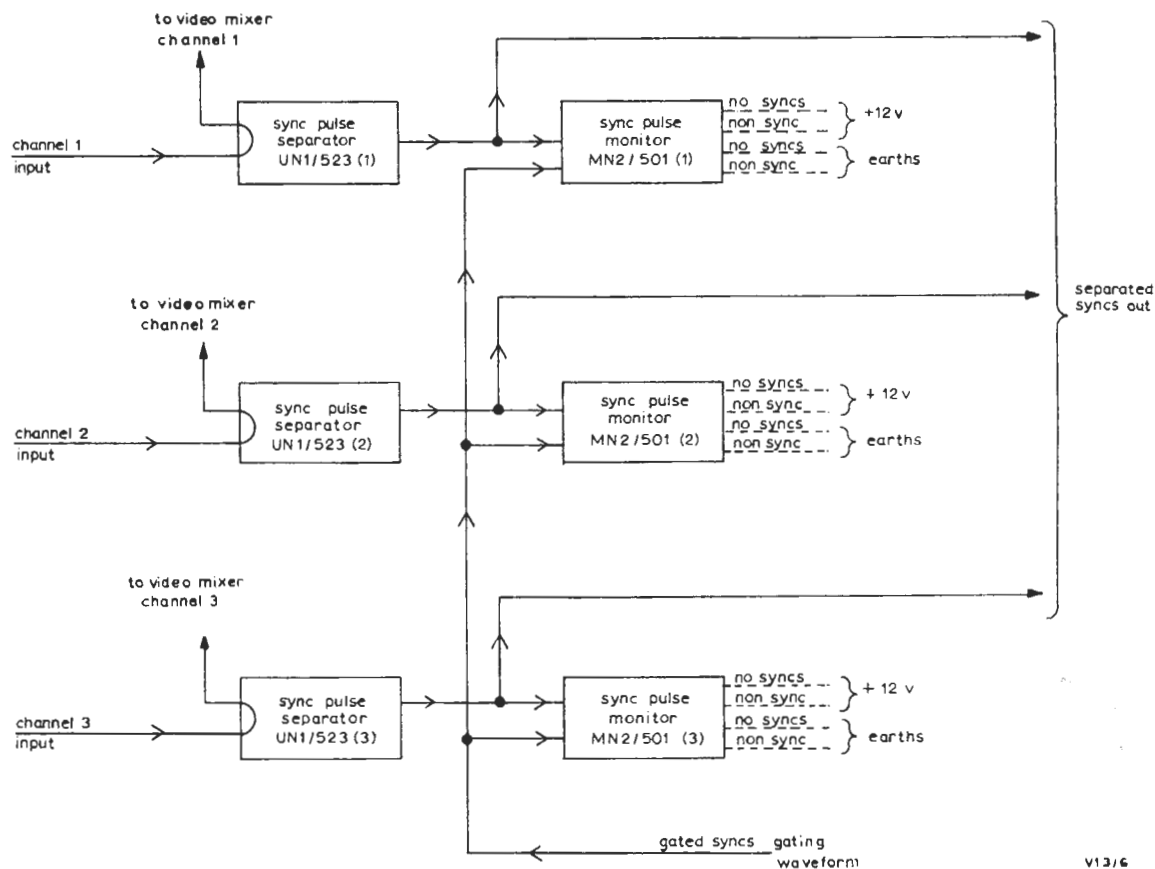

Fig. 20.1 Block Diagram of the PA1/520

Introduction

The PA1/520 accepts up to 3 composite video signals and a gating-pulse waveform and provides feeds of separated syncs¹ and relay logic information^{2,3} which indicates when the inputs are either non-synchronous or not present. The panel operates on the 405, 525 or 625 line-standards without adjustment but with 525-line colour signals a relay must be operated in each of 3 sub-units (UN1/523) as described in Instruction V.14. Power supplies are obtained from an integral PS2/20⁴.

The panel consists of the following sub-units mounted on a PN3/23 chassis:

- 3—Sync Pulse Separator Units UN1/523
- 3—Sync Pulse Monitors MN2/501
- 1—Stabilised Power Supplier PS2/20

General Specification

Signal Inputs

Video	1 volt p-p ± 6 dB
Gating pulse	2 volts p-p ± 1 dB

Signal Outputs

Separated Syncs	2 volts p-p
Non-sync Signals	+12 volts relay-switched connections

Instruction V.13
Part 1, Section 20

No-sync Signals +12 volts
 relay-switched connec-
 tions

Impedances

Video Input high impedance
Gating Pulse Input 75 ohms
Separated Syncs Output 75 ohms

Relay Supply

(525-line colour) -50 volts

Max. Ambient Temperature 45 degrees Centigrade

Weight 18 lbs. (fully equipped)

General Description

A block diagram showing interconnections between the sub-units is given in Fig. 20.1; all components are contained within the sub-units and so a chassis-wiring circuit is not given.

The high-impedance inputs of the UN1/523 sync-pulse separators are bridged across the video inputs to the associated channels of a video mixer. From these they derive feeds of separated sync pulses

which are fed to the associated sync-pulse monitor units and also to a sync-switch panel.

Each sync-pulse monitor compares one of the feeds of separated syncs with a reference feed of gating pulses derived from station syncs. If the two waveforms are coincident (*sync* condition) the unit does not produce an output. If the waveforms are not coincident (*non-sync* condition), or if there is not an output from the preceding sync separator (*no-sync* condition), an output of +12 volts is provided and a relay-switched circuit is completed.

Maintenance

Maintenance instructions are not given for the panel as a whole. For maintenance of the sub-units see the relevant Instructions.

References to Typical Associated Equipment

1. Sync Switch Panel PA18/509.
2. Control Panel PA6/511 and Relay Panel PA17/512.
3. Studio Video Mixing Equipment EP5/503, Instruction V.15.
4. Stabilised Power Supplier P52/20, Instruction G.2.

TES 11/66