

SECTION 7

FIXED-FREQUENCY OSCILLATORS

OSCILLATOR OS/9

The Fixed-frequency Oscillator OS/9 was designed to supply 1-kc/s tone at a fixed level of zero db for lining up programme meters, amplifier detectors and programme chains. Its frequency has now been changed to 900 c/s, to avoid confusion with the transmitter frequency-checking tone which has a frequency of 1 kc/s. Moreover, its function has become largely that of a general-purpose tone source of fixed frequency and reasonably constant output level.

The oscillator design includes features which ensure that both frequency and output level are almost entirely independent of fluctuations in supply voltages or of valve changes. In addition, the output impedance is sufficiently low to ensure that the output level remains sensibly constant irrespective of the load impedance. It is thus possible to feed the output of the oscillator into any amplifier whatever its input impedance may be, without the stabilised zero level of the oscillator being affected.

Circuit Description (Fig. 4)

The oscillator comprises two stages, the oscillator proper and the output stage, each stage using a single valve, Type AC/SP3B.

Oscillator Stage

The oscillator V1 employs resistance-capacitance feedback coupling between grid and anode circuits. The anode is coupled to the grid via the capacitors C1 to C4, the circuit being completed via shunt resistors R1 to R4. R2 takes the form of a pre-set variable 0.5-megohm potentiometer the function of which is to provide frequency adjustment on test.

The following circuit arrangements are used to maintain stability of frequency and of output level of the oscillator stage:—

(i) Constant Screen Volts.

The voltage to the screen grid of the oscillator valve is controlled by a neon voltage stabiliser.

(ii) Grid Volts Control.

Negative bias for the control of grid volts is obtained by rectifying the oscillator

output signal to negative by means of a Westinghouse metal rectifier, Type WX6, the rectified signal being smoothed by the filter circuit comprising C5, C8, R5, the signal being fed to the rectifier via C7.

(iii) Negative Feedback.

Negative current feedback is obtained by omission of the decoupling capacitor from the bias resistor R7.

Output Stage

The oscillator stage is resistance-capacitance coupled to the output stage, gain control being effected by the pre-set potentiometer R13. Negative voltage feedback is applied by means of a third winding on the transformer, the purpose of the feedback being to reduce the output impedance of the valve to 8 kilohms.

The transformer ratio is such that the effective output impedance is 1.35 ohms. With this low output impedance the oscillator, if set to deliver zero level into an open circuit, will suffer a change of only 0.1 db, approximately, for a load impedance of 100 ohms. Since the oscillator is unlikely to be loaded with an impedance lower than 100 ohms, the output level, once set at the required value, remains effectively constant.

In addition to maintaining a low-impedance output, the feedback to this stage makes the stage gain substantially independent of changes in voltage supplies or of valve replacements.

H.T. and L.T. Supplies

The OS/9 is designed to work from either battery or mains supply. For battery supply, the h.t. is taken from a 250 or 300-volt battery and l.t. from a 6-volt accumulator.

In cases where the unit is mounted on an a.c. test bay, supplies are taken from a standard mains unit MU/16.

In the event of a change-over from battery to mains supply, the L.T. circuit of the amplifier must be modified, resistor R24 being short-circuited by the adjustment of its slider and resistors R25 and R26 joined by strapping tags 17 and 18, the junction being extended to tag 13 (negative h.t.) to provide an earthed centre point.

Instruction S.4 Section 7

Meter Circuits

Facilities are provided for switching the meter across shunts to measure the following feeds: V1 Anode, V1 Screen, V2 Anode, V2 Screen, Total Feed, Filament Volts (d.c. only).

In some cases, where a portable meter is provided at the station, the oscillator is not fitted with a feed-meter, the meter terminations being taken to a jack. An Elliott Miniature edgewise 1.5 milliamp type should be used for plugging into this jack.

Valve Data

Valve	Anode Current mA	Screen Current mA	Fil. Volts	Fil. Amps
Stage 1, AC/SP3B	0.4	1.75 (incl. neon)	4	1
Stage 2, AC/SP3B	4.4	1.75	4	1

Total Feed, 8.3 mA.
H.T. Supply, 250 or 300 V.
L.T. Supply, 4 V a.c. or 6 V d.c.

General Data

Neon Stabiliser, ED 1454.
Pilot Lamp, Type P.O. No. 2, 4 V.

Potentiometers

Adj. Frequency (R2).
Type, Morganite Stackpole MNAP 50450.
Resistance, 500 k Ω .
Pre-set Gain (R13).
Type, Morganite Stackpole MNAP 10450.
Resistance, 100 k Ω .

Meter, Miniature Edgewise ED. 1456.

Meter Switch, Yaxley, Type A, 2 bank, 9 position.

OSCILLATORS OS/10 AND OS/10A

The Oscillator OS/10 is a modification of the OS/9. It was originally designed to have a frequency of 1 kc/s and an output level of +4 db, but modern conditions have necessitated modifications of these values to 900 c/s and zero db, respectively. AC/SP3 valves are used in both stages. The normal output load is 60 ohms.

The oscillator is in general use at recording centres, where its main function is to provide a standard fixed level for the lining up of recording programme-input bays.

In general, the performance of the OS/10 is an improvement on that of the OS/9, special pre-

cautions having been taken to maintain stability of frequency and of output level.

Circuit Description (Fig. 5)

Referring to Fig. 5, it will be seen that the oscillator stage is of the feedback type and is similar to that of OS/9, anode to grid coupling consisting of the feedback chain C2-C5, R1-R4.

The working principles of the feedback oscillator have been described on page 7.1. In this section it was stated that the control bias for the oscillator grid was obtained by rectifying the oscillator output signal and returning it to grid. In the OS/10—use is made of amplified delayed control, the control voltage being taken from the anode of the output stage, thus ensuring that the control compensates for level change over the whole circuit, and not merely for level changes in the oscillator itself.

The delay voltage is obtained from the resistors across the neon tube, and the signal obtained from the output via C10 is balanced against this delay voltage; the potential difference thus obtained is rectified and used to control the grid voltage of the oscillator V1 via the resistor R5.

Additional oscillator stability is obtained by the screen grid volts being stabilised by the neon and by introducing negative current feedback by means of the bias resistor R6.

The output level from V2 can be adjusted by means of the variable resistor R14, adjustment of which has the effect of varying the delay voltage. It has been found that with this arrangement the frequency is virtually unaffected by adjustments of the gain control, the maximum frequency variation over the full range of the gain control being of the order of 1 per cent.

The rectifier comprises three Westectors, Type WX6, connected in series, this arrangement being necessary in order to maintain correct impedance conditions, having regard to source and load impedances fixed by other parts of the circuit. Furthermore, in the initial stages of development, the oscillator lacked stability under certain temperature conditions, and the present arrangement of the rectifier has considerably improved stability at all working temperatures.

Since the output-level stability is dependent upon the delay voltage, this stability ultimately depends upon the neon tube producing the delay voltage. The Mullard Neon, Type 7475, was at first found to be most suitable for the purpose, but suitable Osram Neons are now available.

The normal load impedance for the OS/10 is 60 ohms. This is made up by using ten 600-ohm resistors in parallel, but since under normal conditions, the oscillator is required to feed a number of recording room input impedances of 600 ohms, one of the ten shunt resistors is removed for each 600-ohm load required, the tone source jack in each recording room having a 600-ohm load across its inners to maintain correct impedance conditions at all times.

Operation and Maintenance

Complete operating instructions for the OS/10 are contained on a chart attached to the bay on which the oscillator is mounted. For the sake of economy in materials, no feed meter or jack has been provided, but provision is made for checking the feeds when necessary by the removal of the accessible links connected between + HT and the various stages.

Valve Data

<i>Valve</i>	<i>Anode Current mA</i>	<i>Screen Current mA</i>	<i>Fil. Volts</i>	<i>Fil. Amps.</i>
Stage 1, AC/SP3B	0.7	5 (incl. neon)	4	1
Stage 2, AC/SP3B	Anode + Screen Current 6 mA		4	1

Total Feed, 11.7 mA.
H.T. Supply, 300 V.
L.T. Supply, 4 V a.c. or 6 V d.c.

General Data

Neon Stabiliser, Mullard 7475 or Osram ED 1454.

Potentiometer

Type, Morganite Stackpole, MNAP 10450.

Resistance, 100 kΩ.

OSCILLATOR OS/10A

Fundamentally this oscillator is similar to the OS/10. The points of difference are shown in the circuit diagram (Fig. 6) and may be summarised as follows:—

1. Frequency adjustment: Provision is made for adjusting the frequency to 900 c/s by means of a variable potentiometer R2.
2. Metering: A meter switch is fitted instead of the loops used with the OS/10. This provides for measurement of anode and screen currents on both valves, for total feed and for filament volts. The moving arms of the switch are brought out to a feed-meter jack to be used in conjunction with a portable meter, 0-15 milliamps.
3. Grid Resistor: A stabilising resistor is inserted in series with the grid of V2.
4. Output Transformer: This is Type AAL/14RA instead of Type SA42, resulting in a lower output impedance.

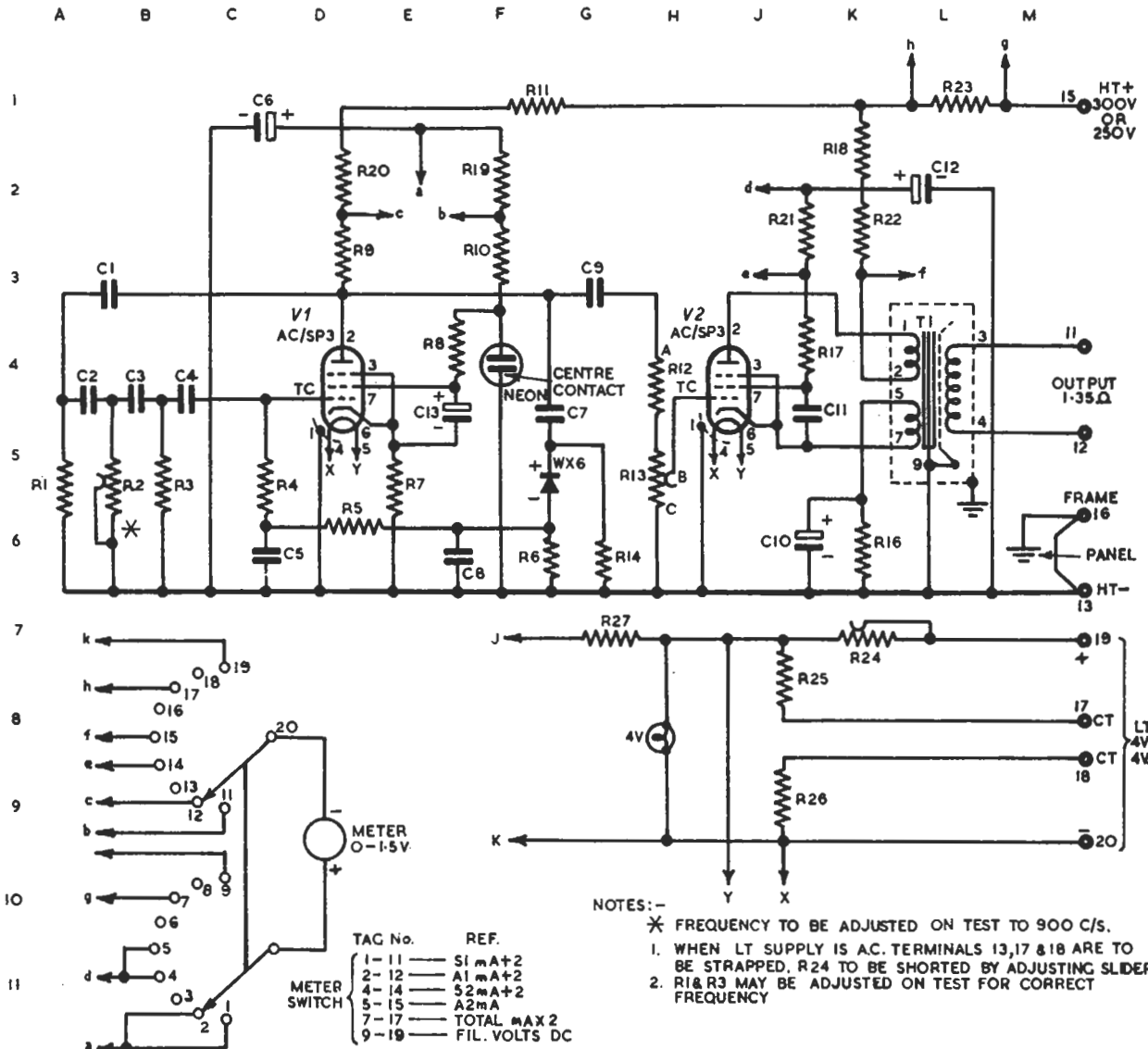

S4O44A/S4/AJP

- NOTES:-
- * FREQUENCY TO BE ADJUSTED ON TEST TO 900 C/S.
 - 1. WHEN LT SUPPLY IS AC. TERMINALS 13,17 & 18 ARE TO BE STRAPPED. R24 TO BE SHORTED BY ADJUSTING SLIDER.
 - 2. R1 & R3 MAY BE ADJUSTED ON TEST FOR CORRECT FREQUENCY

TAG No.	REF.
1-11	S1 mA+2
2-12	A1 mA+2
4-14	S2 mA+2
5-15	A2 mA
7-17	TOTAL MAX 2
9-19	FIL. VOLTS DC

COMP.	LOC.	VALUE	TYPE	COMP.	LOC.	VALUE	TYPE
C1-4	B3A, B4	0.0005 μF		R10	F3	50 000 Ω	
C5	C6	1 "		R11	F1	10 000 "	
C6	C1	16 "		R12	H4	75 000 "	
C7	G4	0.05 "		R13	H5	100 000 "	
C8	F6	0.1 "		R14	G6	1MΩ	
C9	G3	0.05 "		R16	K6	250 Ω	
C10	J6	250 "		R17	J4	80 000 "	
C11	J5	4 "		R18	K1	10 000 "	
C12,13	L2,F4	16 "		R19	F2	33.3 "	
				R20	D2	100 "	
				R21	J2	100 "	
R1	A5	150 000 Ω		R22	K2	33.3 "	
R2	B5	500 000 "		R23	L1	14.3 "	
R3	B5	150 000 "		R24	K7	2 "	
R4	C5	250 000 "		R25	J8	10 "	
R5	D6	50 000 "		R27	G7	3 900 "	
R6	F6	1MΩ					
R7	E5	800 Ω					
R8,9	F4, D3	100 000 "		T1	L4		AL/I7RA

OSCILLATOR OS/9

FIG. 5 S4

S4045A/S4/AJP

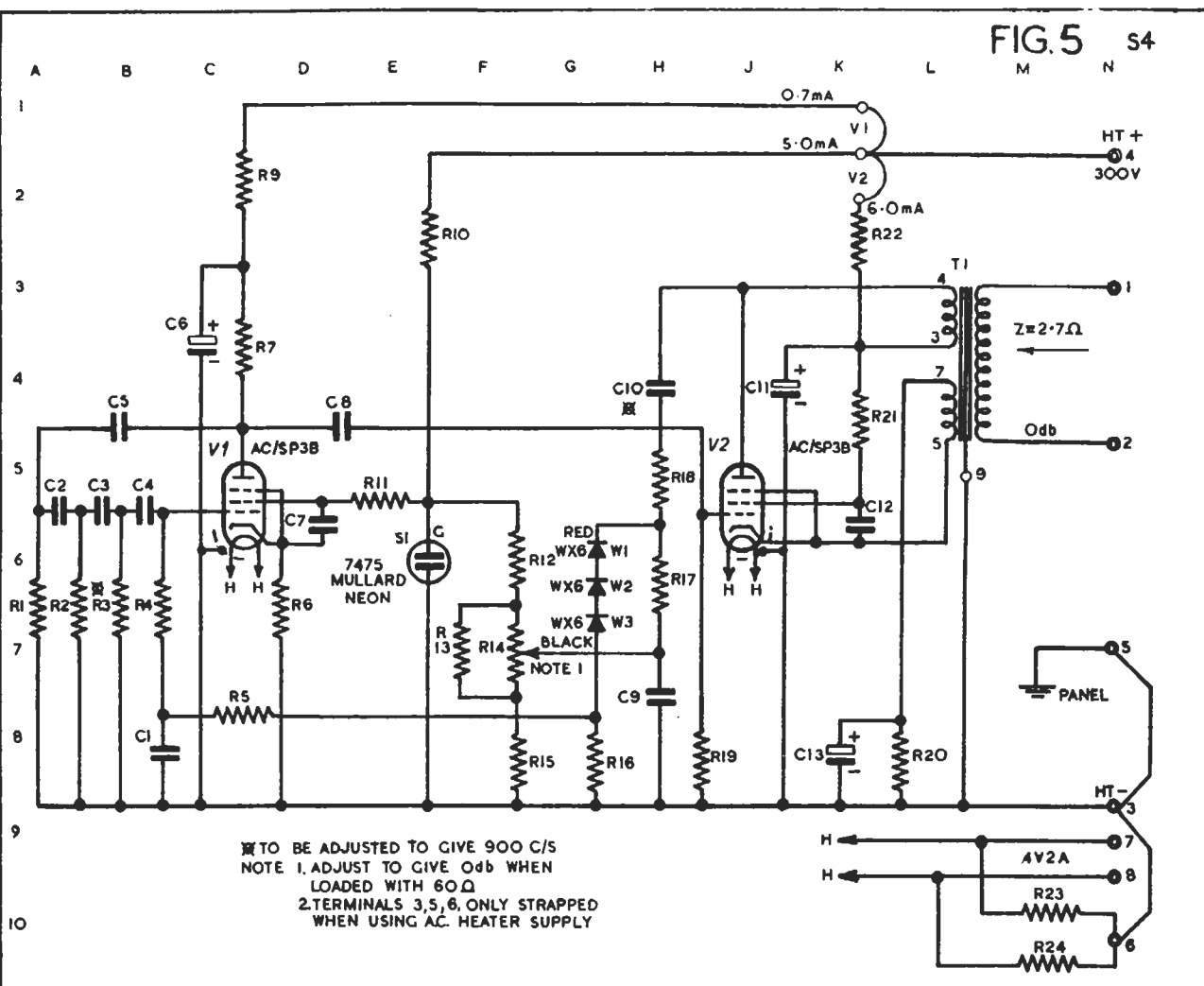

COMP.	LOC.	VALUE	RATING	COMP.	LOC.	VALUE	RATING
C1	B8	1.0 μF		R7	C4	100 000 Ω	
C2,3,4,5	A&B 5	.0005 "		R9	C2	10 000 "	
C6	C4	8 "		R10	E2	40 000 "	
C7	D6	0.5 "		R11,12	E5,F6	100 000 "	
C8	D5	.01 "		R13	F7	50 000 "	
C9	H8	1.0 "		R14	F7	100 000 "	
C10	H4	.005 "		R15	F8	5 000 "	
C11	J4	8 "		R16	G8	250 000 "	
C12	K6	1.0 "		R17,18	H5&6	100 000 "	
C13	K8	250 "		R19	J8	100 000 "	
				R20	L8	250 "	
R1,2	A6	250 000 Ω		R21	K4	100 000 "	
R3	B6	350 000 "		R22	K2	10 000 "	
R4	B6	100 000 "		R23,24	M10	50 "	
R5	C8	50 000 "					
R6	D6	800 "		T1	L4		SA42

OSCILLATOR OS/10

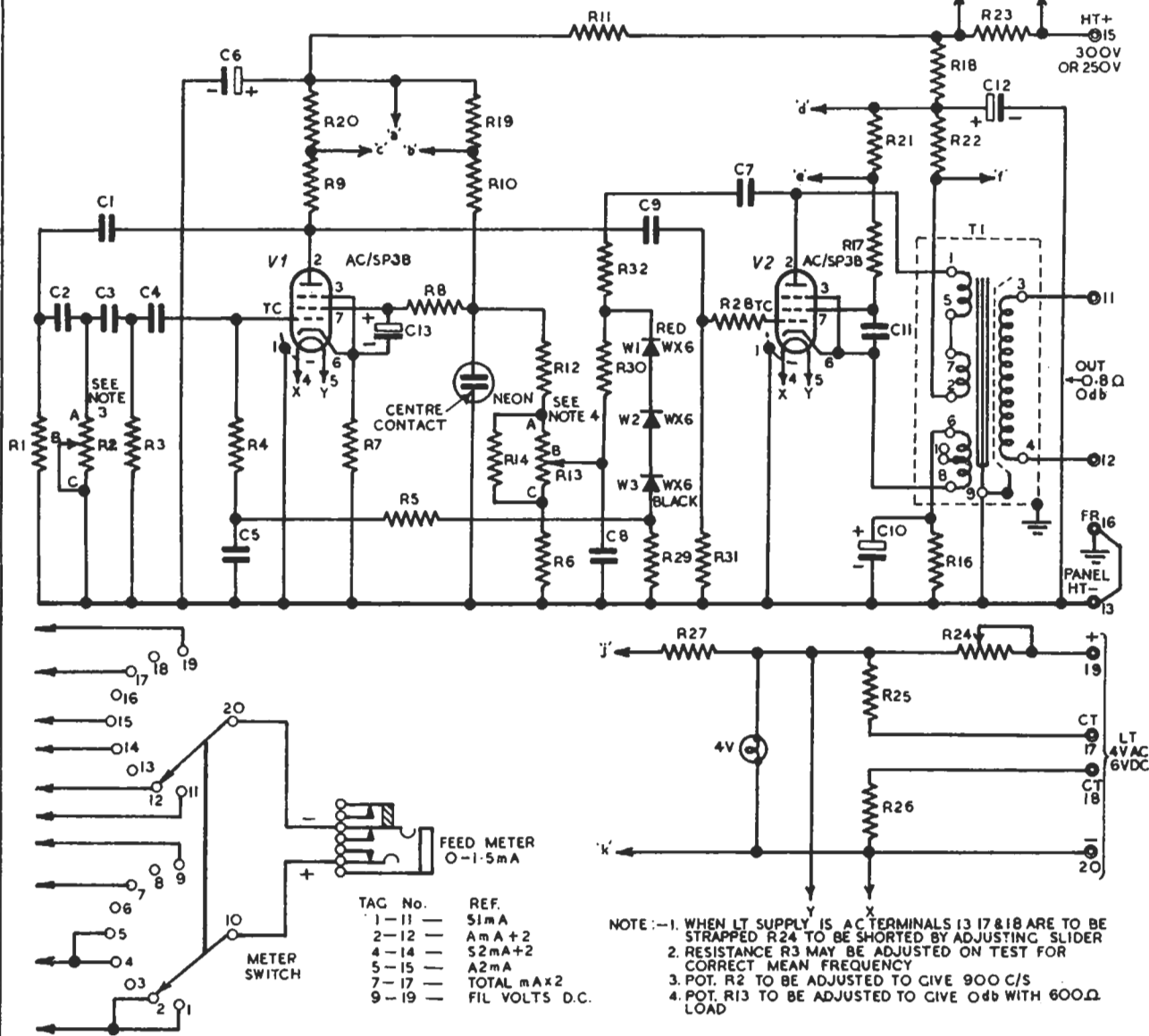

This drawing is the property of the British Broadcasting Corporation and may not be reproduced or disclosed to a third party in any form without the written permission of the Corporation.

TAG No.	REF.
1-11	51mA
2-12	A mA +2
4-14	S2 mA +2
5-15	A2 mA
7-17	TOTAL mA x 2
9-19	FIL VOLTS D.C.

COMPONENT	VALUE	RATING	COMPONENT	VALUE	RATING
C1,2,3,4,	.0005 μF	TCC M	R11	10 000 Ω	ERIE 0.5 W
C5	1 "	" 87	R12,13	100 000 "	R13 = MNAP 10450
C6	16 "	BEC CE 15129	R14	50 000 "	ERIE 0.25 W
C7	.005 "	TCC 431	R16	250 "	" 0.5 W
C8	1 "	" 87	R17	82 000 "	" "
C9	.01 "	" 431	R18	10 000 "	" "
C10	250 "	BEC CE 14680	R19	33.3 "	CARD
C11	4 "	TCC 87	R20,21	100 "	" "
C12 13	16	BEC CE 15129	R22	333 "	" "
			R23	143 "	" "
			R24	2 "	PAINTON 3 B1
R1	330 000 Ω	ERIE 0.25 W	R25,26	10 "	CARD
R2	500 000 "	MNAP 54450	R27	3900 "	PAINTON P301
R3	330 000 "	ERIE 0.25 W	R28	5100 "	ERIE 0.25 W
R4	150 000 "	" "	R29	270 000 "	" "
R5	51 000 "	" "	R30,31	100 000 "	" "
R6	20 000 "	" "	R32	150 000 "	" "
R7	800 "	" 0.5 W			
R8,9	100 000 "	" 0.25 W			
R10	47 000 "	1 W	T1		AAL/14RA

OSCILLATOR OS/10A